

# Wind/diesel with dump load controlling, high wind penetration and desalination

Vestesen A/S offers the world's leading technology for wind or diesel systems with high wind penetration. The projects range from 100 to 10,000 kW and the company acts in a global market, where worldwide contacts make it possible to work on all continents in very remote areas. Often, the electricity in these remote areas is not connected to a grid and so it can be unstable or very expensive. This gives Vestesen the opportunity to deliver individually adapted wind/diesel systems producing inexpensive, quality electricity 100% of the time...

The Danvest Wind/Diesel (WD) systems with high wind penetration for "Off-Grid" operation are based on normal diesel generator sets fitted with Danvest WD equipment for backing up wind turbines from 0 to 100% wind energy supply in both automatic and continuous operation.

- When the wind energy is sufficient to supply all consumption - the engine is clutched out and stopped. The alternator remains connected to the busbar for the control of:
  - a) Reactive power, voltage and frequency (dump load controlling)
  - b) Function as flywheel in the rotatory system
- When wind is decreasing, or if the consumer is increasing, the engine is started and clutched in automatically again in one to three seconds.
- Dump load controlling – fast, dynamic load balance between the fluctuating

wind energy and the varying consumer supply thus having stable voltage and frequency – 50/60 Hz  $\pm 0,1-0,3$  Hz, so that the resulting fluctuation is negligible.

- Fitted with the Danvest WD equipment, the engines are able to operate at low load for longer periods thus maintaining normal service intervals. At low load operation, the 'gen.set' functions as a very soft dump load.

With this method a yearly fuel saving of up to 50-90% can be obtained, thus saving so much fuel, that the savings can more than pay for the cost of wind turbines and the WD equipment.

The cooling system obtains all waste and surplus wind energy for water desalination/purification or central heating. In this way, the highest plant efficiency is obtained. Raw water feeding systems are integrated in the total cooling system and both Reverse Osmosis (RO) and distillation processes

and central heating can be combined for obtaining the high plant efficiency, up to 95%

The Danvest WD concept, which is especially designed for remote areas, is containerised and simple to install and operate.

Furthermore, the Danvest system offers a complete infrastructure solution with electrical energy, pure water and/or central heating in a compact turnkey system.

Existing wind power installations can be converted to WD systems for grid stabilisation and backup with continuous power supply of the highest quality. Installations can be extended with water purification/desalination and central heating production.

See *RISO documentation Test reports: Riso-I-988(EN) and Riso-I-1960(EN)*

Cont'd on p 76.

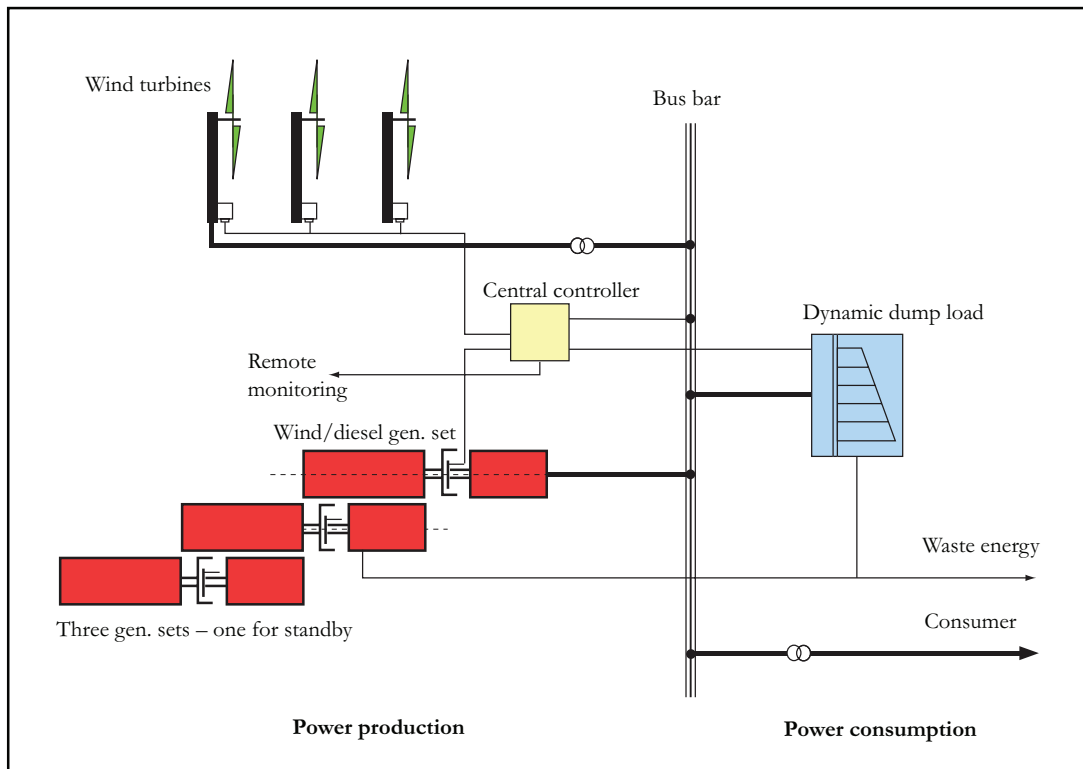

## WDS2 A/S - Desalination Systems

Vestesen A/S, previously Danvest Energy, is also a part of WDS2 A/S - specialising in wind/diesel desalination systems.

The desalination systems are designed as containerised modules with production capacities from 10 to 3,800 m<sup>3</sup>/day, per unit. The modules can supply fresh water for irrigation, municipal basis water supply, industrial process water and drinking water of high quality.

The desalination modules are based on state of the art technologies within RO processes, ultra filtration, distillation and disinfection.

Vestesen A/S also offers stand-alone high efficient diesel-based containerised water purification systems for remote areas without adequate wind conditions.

### Turnkey solutions

WDS2 does all designs and engineering for the total system in cooperation with acknowledged manufacturers for wind turbines (Vestas Wind Systems), desalination equipment (WDS2), finance houses, local contractors. WDS2 supplies total turnkey solutions.

### Capacity:

Electric Power	100 - 6,000 kW/h
Fresh water	10 - 60,000 m <sup>3</sup> /day
Standard module	3,800 m <sup>3</sup> /day - 1,000,000 gallon/day

### Summary

The preconditions for introducing wind energy conversion systems in isolated grids give an economical motivation to search for alternative technology, which can replace energy production based on expensive fuel.

Vestesen A/S has extensive know-how based on experience with design, engineering (diesel engine know-how), production, installation, operation and implementation of WD systems. And the company has been at the forefront of innovative developments and design of WD concepts to a viable and commercial extent.

The following key-features for the Danvest WD system with design philosophy for continuous development and operation strategies in order to be able to convince the

power supplier (who often is sceptical about implementing a new technology for power supply) that high availability of operation and maintenance also is assured by the Danvest WD system:

- The basis diesel generator sets operate independently but parallel with the WD system. This means that if a breakdown occurs for the WD equipment it is cut out and the basis diesel based generator sets continue operating
- The WD system must be simple and robust – making it possible for existing staff to operate and maintain after a short introduction and training
- The WD system incl. the wind turbines are based on worldwide known and proven technology securing high reliability of operation and maintenance
- The WD system operates automatically and continuously – often replacing manual and periodic operation
- The WD system takes over the full responsibility for the continuous power supply of high quality
- The service system ensures optimum operation condition through the remote worldwide communication system parallel with the similar systems for the wind turbines
- Danvest dynamic dump load controlling ensures a governing of the total rotatory system, where heavy masses from the wind turbines and diesel generator comprises a dynamic frequency system with the following effects:
  - a) Minimise inertia gust
  - b) Minimise wearing at bearings, couplings and gear wheels
  - c) Minimise transients in the electric system
  - d) Stabilise fluctuations from wind and consumers

### Optimal design

With unique experience in the field of wind diesel installation for given locations, a calculation program is developed by means of which Vestesen A/S can provide an optimal system design and set up the most optimal component combination of wind and engine power capacities for the local installation to obtain the lowest kWh price - for feasibility studies.

### Yearly wind penetration

Both yearly wind penetration and fuel savings are a calculated amount waste heat,

and surplus wind energy is calculated for utilisation.

### Low load operation

With yearly wind penetration from 50-90%, the WD gen.set often operates at 0-30% load. To ensure optimal operation with normal standard service intervals, the WD engine is preheated, prepressured and conditioned so the engine can be “parked“ at 0 ±5% load in the main controlling system. It is ready for taking up load peaks and it stops when the wind energy is sufficient for power supply with wind alone.

This facility case will make the high fuel saving percentage go up to 100% without using power recovering systems.

### High wind penetration

With optimal design and engineering, the lowest yearly kWh cost is obtained, where the wind turbines capacity often will be 120-150% of the maximum consumer load during the day. Surplus wind energy will only take place at high wind, which only occurs rather few hours over the year compared with the many hours around average wind, which will cover the main part of the average power consumption over the year. See our homepage.

### Power quality

Any operation mode is within predefined limits:

Frequency	50/60 Hz ± 0.1-0.3 Hz
Voltage	400/480-volt ± 3-6%
Power factor	0.8 - 0.98

### PC based-remote monitoring system

For remote control via the common telephone network, parallel with the systems for the wind turbines. In this way the WD plant (engine condition) can be controlled centrally in a service centre with skilled engineers.

### Lifetime

Up to 20 years for the main components including the diesel engine because of the high wind penetration with reduced diesel engine operation. ■

For further information visit: [www.danvest.com](http://www.danvest.com)